

1 2 3 4 5 6 7 8

REVISIONS		
ISS	ZONE	DESCRIPTION\PER REQUEST\DATE
B	A-1	NO.4 WAS CHANGED\RD-DM89051801\05-18-00'
C	A-1	NO.5 WAS CHANGED\RD-DM89061701C\06-17-00'

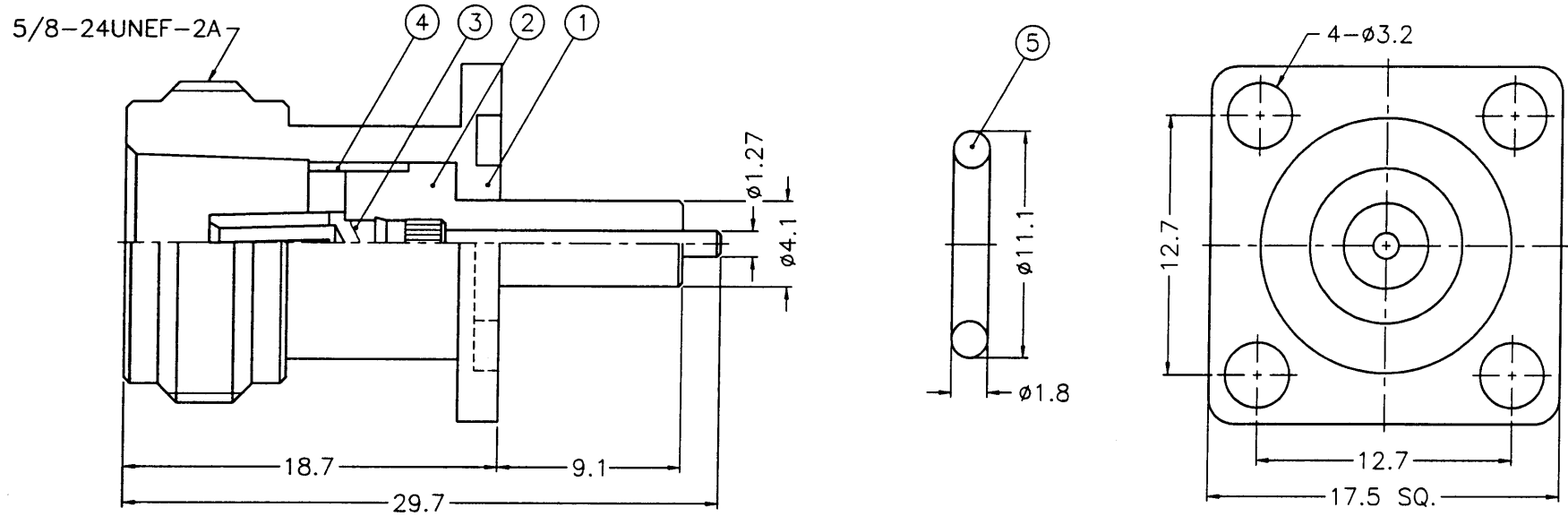

F
E
D
C
B
A



NOTES: FINISH (PLATING THICKNESS IN MICRO-INCHES)
 1. BRASS PER QQ-B-626
 2. NICKEL PL. 100 MIN. THICK OVER COPPER STRIKE
 3. PHOSPHOR BRONZE PER QQ-B-750
 4. GOLD PL. 3 MIN. THICK OVER NICKEL PL. 100 MIN. THICK OVER COPPER STRIKE
 5. TEFLON MIL-P-19468
 6. SILICONE, CLASS 2a GRADE 70 OF SPEC. ZZ-R-765E



DIMENSIONS ARE IN MILLIMETERS					PART NO.				Amphenol - Kai Jack			
5	GASKET	NOTE 6	RED	1	GS-111/75XD18-B	UNLESS OTHERWISE SPECIFIED TOLERANCES				TAINAN TAIWAN		
4	RING	NOTE 1	NOTE 2	1	N-JACK-LR1	0.5-6 = ±0.2	APPROVED	<i>A. K. C.</i>	DATE	06-20-00'	TITLE	
3	CONTACT PIN	NOTE 3	NOTE 4	1	N7550-3	6-30 = ±0.4	CHECKED	<i>Andy. C.</i>	DATE	06-20-00'	N PANEL RECEPT. JACK	
2	INSULATOR	NOTE 5	NATURAL	1	N7550-2T-50	30-120 = ±0.6	DRAWN	<i>Joye. Y.</i>	DATE	06-20-00'	DRAWING NO.	
1	BODY	NOTE 1	NOTE 2	1	N7550-1	120-315 = ±1					KJ-N6551E1-NT3G-50	
NO.	DESCRIPTION	MATERIAL	FINISH	Q'TY	DRAWING NO.	315-1000 = ±1.6					FILE NO.	
						1000-2000 = ±2.4	SCALE	3/1	ISSUE	C	F:\DWG\N\6551E1\50\NT3G	

1 2 3 4 5 6 7 8

112111 BRD-DR1901