

REVISIONS		
ISS	ZONE	DESCRIPTION\APPROVED\DATE
A1	B-7	ADDED TOOLS SHOW\N/A\12-05-00'

業務部

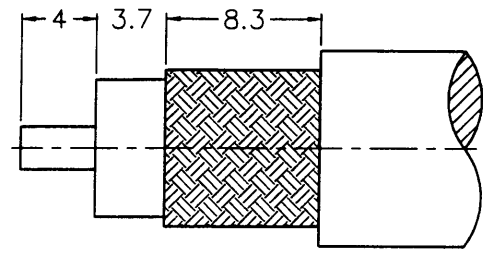

RECOMMENDED CABLE STRIPPING DIM'S

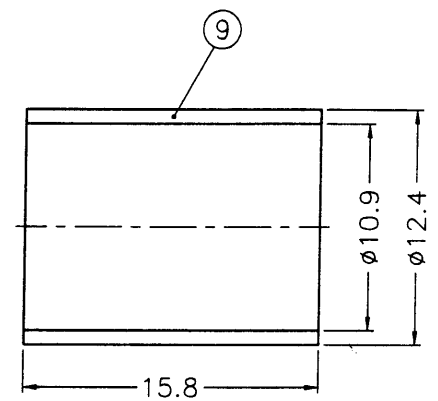
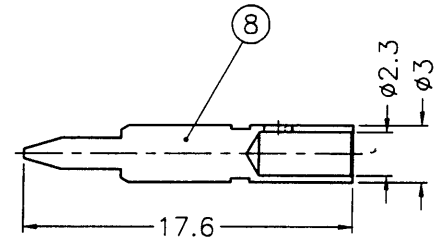
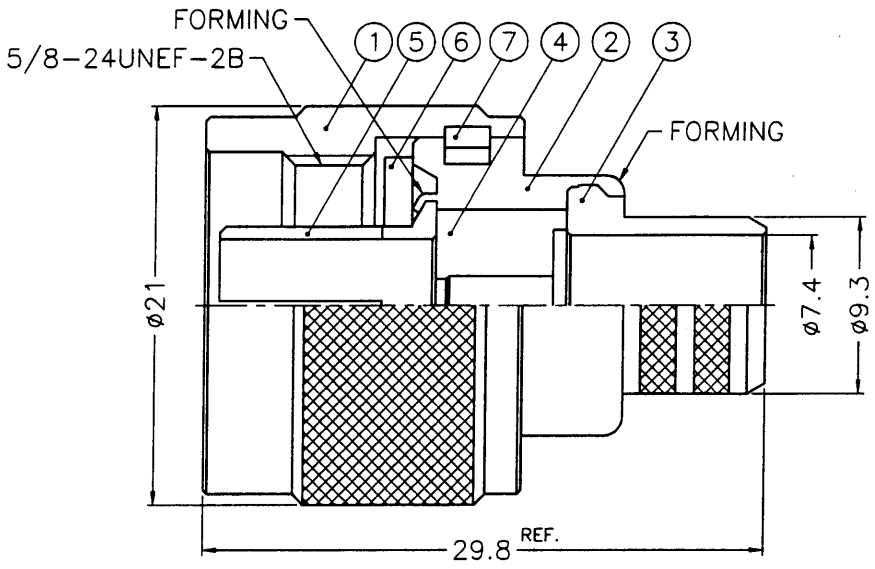

NOTES: FINISH (PLATING THICKNESS IN MICRO-INCHES)
 1. BRASS PER QQ-B-626
 2. NICKEL PL. 100 MIN. THICK OVER COPPER STRIKE
 3. GOLD PL. 3 MIN. THICK OVER NICKEL PL. 100 MIN. THICK OVER COPPER STRIKE
 4. TEFLON MIL-P-19468
 5. JIS H 3250, C 2700

- 1. CRIMPED FERRULE
HEX CRIMP SIZE .429"
- 2. CRIMPED CONTACT PIN
HEX CRIMP SIZE .100"

2000. 12. 06
設計部

NO.	DESCRIPTION	MATERIAL	FINISH	Q'TY	DRAWING NO.
9	FERRULE	NOTE 5	NOTE 2	1	FR-124/109X158
8	CONTACT PIN	NOTE 1	NOTE 3	1	N5000-8-3/23-B
7	RETAINER RING	SUS 304	NATURAL	1	N5000-7-C
6	GASKET	SILICONE	RED	1	GS-156/8X15
5	CONTACT BODY	NOTE 1	NOTE 2	1	N5000-5
4	INSULATOR	NOTE 4	NATURAL	1	N5000-4T-50-A
3	BARREL	NOTE 1	NOTE 2	1	N5000-3-93/74
2	BODY	NOTE 1	NOTE 2	1	N5000-2
1	SHELL	NOTE 1	NOTE 2	1	N5000-1-B

DIMENSIONS ARE IN MILLIMETERS
 UNLESS OTHERWISE SPECIFIED TOLERANCES
 0.5-6 = ±0.2
 6-30 = ±0.4
 30-120 = ±0.6
 120-315 = ±1
 315-1000 = ±1.6
 1000-2000 = ±2.4
 SCALE 2.5/1 ISSUE A1

PART NO.	
APPROVED	<i>[Signature]</i> DATE 12-05-00'
CHECKED	<i>[Signature]</i> DATE 12-05-00'
DRAWN	<i>[Signature]</i> DATE 12-05-00'

Amphenol - Kai Jack TAINAN TAIWAN	
TITLE	N CRIMP PLUG (FOR BELDEN 8237, 9251)
DRAWING NO.	KJ-N1121A1-NT3G-8U-50
FILE NO.	F:\DWG\N\1121A1\8U-50\NT3G

F
E
D
C
B
A

F
E
D
C
B
A