

REVISIONS		
ISS	ZONE	DESCRIPTION\PER REQUEST\DATE
B	A-3	NO.4 WAS CHANGED\RD-DM91020501K\02-05-02'
		NO.3 WAS CHANGED\RD-DM91052301K\05-23-02'
		NO.8 WAS CHANGED\RD-DM91082201W\08-22-02'

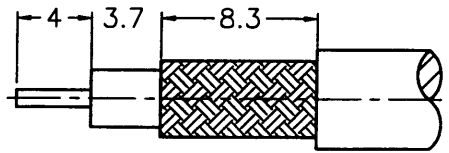

SALES

RECOMMENDED
CABLE STRIPPING DIM'S
(建議剝線尺寸)

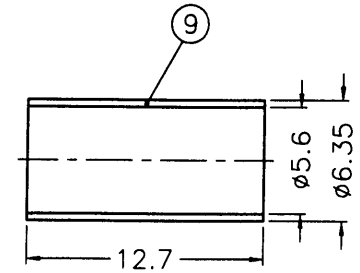
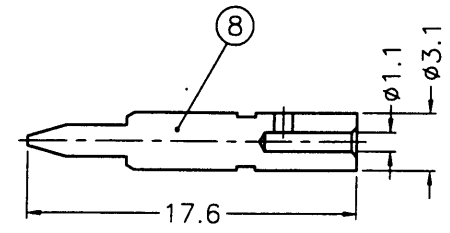
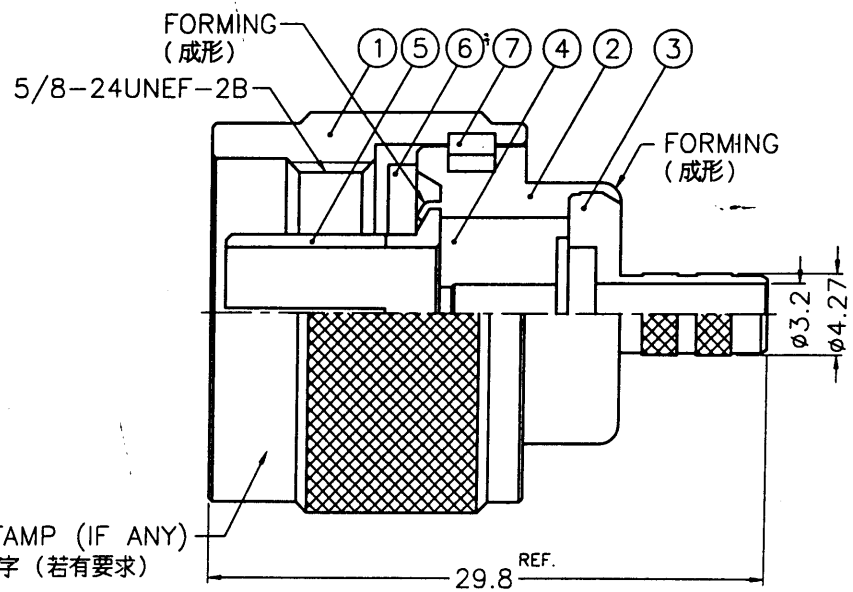

STAMP (IF ANY)
噴字 (若有要求)

- NOTES: FINISH (PLATING THICKNESS IN MICRO-INCHES)
- BRASS PER QQ-B-626
 - NICKEL PL. 100 MIN. THICK OVER COPPER STRIKE
 - GOLD PL. 3 MIN. THICK OVER NICKEL PL. 100 MIN. THICK OVER COPPER STRIKE
 - TEFLON MIL-P-19468
 - JIS H 3250, C 2600

ISSUED
2002. 8. 23
F&D

- CRIMPED FERRULE
HEX. CRIMP SIZE .213"
- CONTACT PIN TO SOLDER

9	FERRULE	NOTE 5	NOTE 2	1	FR-635/56X127
8	CONTACT PIN	NOTE 1	NOTE 3	1	N5000-8-31/11-C
7	RETAINER RING	SUS 304	NATURAL	1	N5000-7-C
6	GASKET	SILICONE	RED	1	GS-156/8X15
5	CONTACT BODY	NOTE 1	NOTE 2	1	N5000-5
4	INSULATOR	NOTE 4	NATURAL	1	RF10028-001-4-B
3	BARREL	NOTE 1	NOTE 2	1	N5000-3-427/32-B
2	BODY	NOTE 1	NOTE 2	1	N5000-2
1	SHELL	NOTE 1	NOTE 2	1	N5000-1-B

DIMENSIONS ARE IN MILLIMETERS			PART NO.	
UNLESS OTHERWISE SPECIFIED TOLERANCES			APPROVED	DATE
0.5-6	= ±0.2		<i>ganckey</i>	08-22-02'
6-30	= ±0.4		CHECKED	DATE
30-120	= ±0.6		<i>Ken</i>	08-22-02'
120-315	= ±1		DRAWN	DATE
315-1000	= ±1.6		<i>Ken</i>	08-22-02'
1000-2000	= ±2.4			

Amphenol - Kai Jack
TAINAN TAIWAN

TITLE N CRIMP PLUG
(FOR RG-55/U,142A/U,223/U,400/U)

DRAWING NO. KJ-N1121A1-NT3G-223U-50

ITEM NO. 031121AAA26NA5F

7 PD PR 11592 8